

# DRA200 SERIES

This catalogue is revised and/or updated as of Jan. 2024 and supersedes any old ones.  
이 카탈로그는 2024년 1월에 개정 또는 업데이트 되었으며 이전의 카탈로그를 대체합니다.

## DRA200 SERIES



## FUNCTIONAL SCHEMATIC

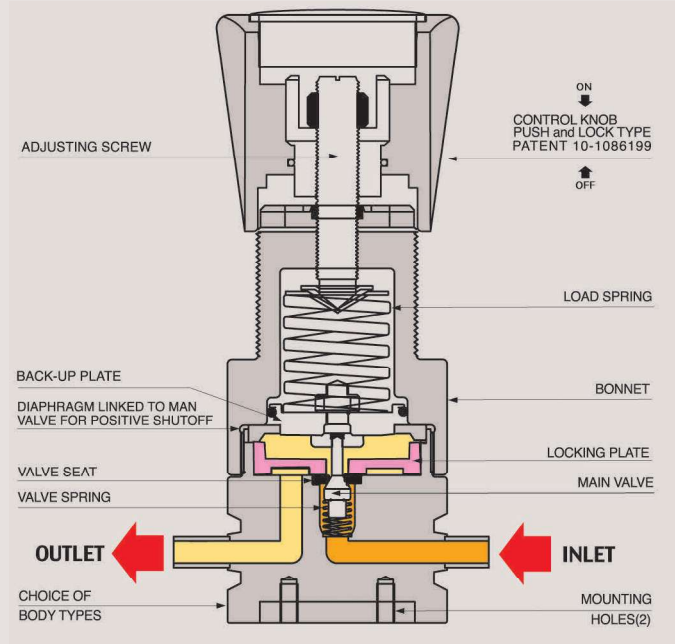

### DRA200(Tied type)

#### UHP Tied Diaphragm Low Pressure VCR type (1/4" 3/8" 1/2" 3/4")

DRA200시리즈는 초고순도 반도체 제조용 Gas Cabinet, 특수 가스 라인, Valve Manifold Boxes, 기타 연구실 등에 적합하도록 개발된 Tied type 저압용 Pressure Reducing Regulator입니다.

- 다이아프램과 메인밸브를 연결시킨 Tied-Diaphragm 타입으로 밸브시트에 이물질이 형성되더라도 압력이 누설되지 않도록 최고의 안전성을 고려하여 설계된 제품입니다.
- 이물질 발생을 방지하기 위해 DI water 세정과 표면은 B.A. 25Ra, E.P. 10Ra 또는 5Ra microinch등급까지 처리되었습니다.
- 특히 독성 가스, 발화성 가스, 고부식성 가스 등으로 인해 다이아프램이 파열되는 것로부터 보호하는데 유용합니다.
- Locking-plate seal system (당사 특허 #10-1086199) 적용으로 파티클 (particle) 방지 기능이 더욱 강화되었습니다.
- 입구 압력은 3,000psig(210bar) or 600psig(42bar)이고 출구압력은 5psig(0.3bar)에서 최대 250psig(17bar)까지 사용 가능하며, 용도에 따라 2-ports, 3-ports 또는 4-ports 선택 가능합니다.
- 용접, 조립, 실험, 세정 등 모든 공정은 100-class와 10-class 크린룸에서 작업이 이루어 집니다.
- 사용 중 가스라인이나 외부의 미세 진동 등으로 인하여 초기 압력 셋팅 값이 미세하게 변동하는 현상을 완전히 해결한 당사 Push and Lock 조절 손잡이 (당사 특허 #10-1086199)를 적용하여 사용하기에 더욱 편리합니다. 조절 손잡이를 누르면 (lock) 압력 셋팅 값이 변하는 것을 완전히 방지할 수 있고, 손잡이를 앞으로 당기면 (unlock) 자유롭게 원하는 압력으로 다시 셋팅할 수 있습니다.

**DRA 200 Series** is an UHP low pressure reducing regulator with B.A. 25Ra, E.P. 10Ra, or E.P. 5Ra surface finishes and applicable for gas cabinet for semiconductor manufacturing, specialty gases, valve manifold boxes, and other research labs, etc. Inlet pressures are 3,000psig(210bar) or 600psig(42bar) and outlet pressures are 5psig

(0.3bar) up to 250psig (17bar).

With DRASTAR's patented (patent #10-1086199) "push and lock type handle", you can operate it easily and stably; "locking" by pushing down the handle will prevent any slight change of pre-set pressure value, which could possibly be caused by any vibration from gas pipeline or ambient applications and the other way "unlocking" by pulling it back enables you to adjust the pressure value freely again.

#### Features and Applications

- 1/4", 3/8", 1/2", and 3/4" VCR type
- Tied-diaphragm design for positive shut-off and protecting the rupture of diaphragm
- Surfaces finishes to B.A. 25Ra, E.P. 10 Ra or E.P. 5 Ra microinch
- Push and lock type handle (DRASTAR patent No. 10-1086199) mounted
- Threadless type: enhanced particle prevention by adopting the locking-plate seal system (DRASTAR patent #10-0753280)
- All works of welding, assembly, test and cleaning are performed in class 100 and class 10 clean-rooms
- Design proof pressure: 150% of maximum rated
- Applicable for Semiconductor manufacturing gas line, toxic gases, pyrophoric gases, and high corrosive gases

#### 권장사항

각 제품들은 최고의 안전성과 쉬운 조작성을 고려하여 제작되었습니다. 그러나 가장 안전하고 효율적인 Regulator 사용을 위해서는 실제 사용 압력을 각각 모델의 사용 압력에 25% ~ 75% 이내에서 사용하면 가장 이상적인 압력을 사용할 수 있습니다. 정밀하고 원활한 작동과 제품의 수명 연장을 위해서는 각 모델의 사용 범위 내에서 사용하기를 적극 권장합니다.

Each product is manufactured taking into consideration of the best safety and easy manipulation. However in order to use the regulator in most safe, effective, precise and smooth way and prolong its life time, you are recommended to use the actual pressure within the range of 25% ~ 75% of its rated pressure.

**REFERENCE**

Contents in the catalogue including specifications, performance data, etc. can be changed without prior notice in the course of continuous upgrading and improvement of the products.  
 사양서와 성능데이터 등 카탈로그에 있는 내용은 당사 제품의 지속적인 업그레이드 및 개선의 과정에서 사전 예고 없이 변경될 수 있습니다.

**INSTALLATION DIMENSIONS**

METRIC EQUIVALENTS ARE IN PARENTHESES

■ GAUGE PORT OPTIONS

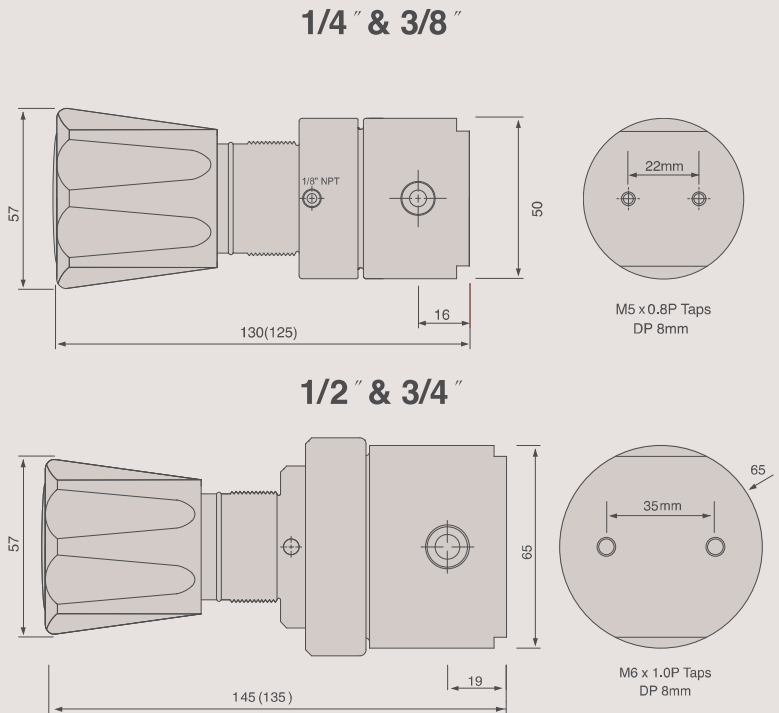
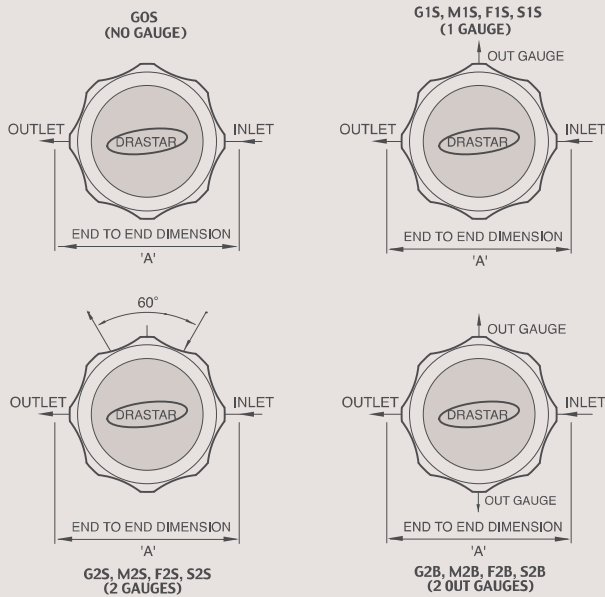

**Ordering Information**

**DRA200 - A 025 S - H P S - 4MS - G0S**

<p><b>BASIS SERIES</b></p>	<p><b>BODY MATERIAL &amp; SURFACE FINISH</b>                  A = 316L, B.A ..... 25Ra                  B = 316L, E.P. .... 10Ra                  C = 316L, E.P. (P.E.P) ..... 5Ra                  D = 316L, E.P. VAR ..... 10Ra                  E = 316L, E.P. VAR(P.E.P) ..... 5Ra</p> <p>B.A.= Brigh Annealed., E.P.= Electropolished.</p>	<p><b>OUTLET PRESSURE RANGE</b>                  025 = 1-25psi (.1-1.7bar)                  050 = 1-50psi (.1-3.5bar)                  100 = 1-100psi (.1-7bar)                  250 = 1-250psi (.2-17bar)</p>	<p><b>DIAPHRAGM MATERIAL</b>                  S = STS 316L                  H = Hastelloy-C</p>	<p><b>MAX. INLET PRESSURE</b>                  H = 3000psi(210bar)                  L = 600psi(42bar)</p>	<p><b>SEAT MATERIAL</b>                  P = PCTFE                  T = Teflon                  V = Vespel</p>	<p><b>GAUGE PORTS OPTIONS</b></p> <table border="0"> <tr> <td>G0S = None ..... 0</td> <td>F1S = 1/4" Female Swivel..... 1</td> </tr> <tr> <td>G1S = 1/4" H.P.I.C..... 1</td> <td>F2S = 1/4" Female Swivel..... 2</td> </tr> <tr> <td>G2S = 1/4" H.P.I.C..... 2</td> <td>F2B = 1/4" Female Swivel..... 2</td> </tr> <tr> <td>G2B = 1/4" H.P.I.C..... 2</td> <td>M2S = 1/4" Male Swivel..... 2</td> </tr> <tr> <td>M1S = 1/4" Male Swivel. 1</td> <td>M2B = 1/4" Male Swivel..... 2</td> </tr> </table>	G0S = None ..... 0	F1S = 1/4" Female Swivel..... 1	G1S = 1/4" H.P.I.C..... 1	F2S = 1/4" Female Swivel..... 2	G2S = 1/4" H.P.I.C..... 2	F2B = 1/4" Female Swivel..... 2	G2B = 1/4" H.P.I.C..... 2	M2S = 1/4" Male Swivel..... 2	M1S = 1/4" Male Swivel. 1	M2B = 1/4" Male Swivel..... 2	<p><b>INLET / OUTLET PORTS SIZE &amp; Type "A" ±1.0mm</b></p> <table border="0"> <tr> <td>4HP = 1/4" H.P.I.C</td> <td></td> </tr> <tr> <td>4MS &amp; 4FS = 1/4" Male, Female Swivel</td> <td>94mm</td> </tr> <tr> <td>4ML &amp; 4FL = 1/4" Male, Female Swivel</td> <td>110mm</td> </tr> <tr> <td>8MS &amp; 8FS = 3/8" Male, Swivel</td> <td>120mm</td> </tr> <tr> <td>8ML &amp; 8FL = 3/8" Male, Female Swivel</td> <td>140mm</td> </tr> <tr> <td>2MS &amp; 2FS = 1/2" Male, Female Swivel</td> <td>140mm</td> </tr> <tr> <td>2ML &amp; 2FL = 1/2" Male, Female Swivel</td> <td>180mm</td> </tr> <tr> <td>2FSS 1/2 = Male, Female Swivel</td> <td>122mm</td> </tr> <tr> <td>3MS &amp; 3FS = 3/4" Male, Female Swivel</td> <td>160mm</td> </tr> <tr> <td>3ML &amp; 3FL = 3/4" Male, Female Swivel</td> <td>000mm</td> </tr> <tr> <td>IMF = In Port Male / Out Port Female</td> <td>000mm</td> </tr> <tr> <td>IFM = In Port Female / Out Port Male</td> <td>000mm</td> </tr> <tr> <td>4TS = 1/4" Tube Stubs</td> <td>94mm</td> </tr> <tr> <td>2TS = 1/2" Tube Stubs</td> <td>120mm</td> </tr> <tr> <td>3TS = 3/4" Tube Stubs</td> <td>160mm</td> </tr> </table>	4HP = 1/4" H.P.I.C		4MS & 4FS = 1/4" Male, Female Swivel	94mm	4ML & 4FL = 1/4" Male, Female Swivel	110mm	8MS & 8FS = 3/8" Male, Swivel	120mm	8ML & 8FL = 3/8" Male, Female Swivel	140mm	2MS & 2FS = 1/2" Male, Female Swivel	140mm	2ML & 2FL = 1/2" Male, Female Swivel	180mm	2FSS 1/2 = Male, Female Swivel	122mm	3MS & 3FS = 3/4" Male, Female Swivel	160mm	3ML & 3FL = 3/4" Male, Female Swivel	000mm	IMF = In Port Male / Out Port Female	000mm	IFM = In Port Female / Out Port Male	000mm	4TS = 1/4" Tube Stubs	94mm	2TS = 1/2" Tube Stubs	120mm	3TS = 3/4" Tube Stubs	160mm	<p><b>FLOW CAPACITY</b></p> <table border="0"> <tr> <td>S = Cv 0.06 Standard (Inlet 3000psi) (1/4")</td> </tr> <tr> <td>O = Cv 0.2 Optional (1/4")</td> </tr> <tr> <td>S = Cv 0.2 Standard (3/8")</td> </tr> <tr> <td>S = Cv 0.5 Standard (1/2")</td> </tr> <tr> <td>O = Cv 1.0 Optional (1/2")</td> </tr> <tr> <td>S = Cv 1.2 Standard (3/4")</td> </tr> </table>	S = Cv 0.06 Standard (Inlet 3000psi) (1/4")	O = Cv 0.2 Optional (1/4")	S = Cv 0.2 Standard (3/8")	S = Cv 0.5 Standard (1/2")	O = Cv 1.0 Optional (1/2")	S = Cv 1.2 Standard (3/4")
G0S = None ..... 0	F1S = 1/4" Female Swivel..... 1																																																					
G1S = 1/4" H.P.I.C..... 1	F2S = 1/4" Female Swivel..... 2																																																					
G2S = 1/4" H.P.I.C..... 2	F2B = 1/4" Female Swivel..... 2																																																					
G2B = 1/4" H.P.I.C..... 2	M2S = 1/4" Male Swivel..... 2																																																					
M1S = 1/4" Male Swivel. 1	M2B = 1/4" Male Swivel..... 2																																																					
4HP = 1/4" H.P.I.C																																																						
4MS & 4FS = 1/4" Male, Female Swivel	94mm																																																					
4ML & 4FL = 1/4" Male, Female Swivel	110mm																																																					
8MS & 8FS = 3/8" Male, Swivel	120mm																																																					
8ML & 8FL = 3/8" Male, Female Swivel	140mm																																																					
2MS & 2FS = 1/2" Male, Female Swivel	140mm																																																					
2ML & 2FL = 1/2" Male, Female Swivel	180mm																																																					
2FSS 1/2 = Male, Female Swivel	122mm																																																					
3MS & 3FS = 3/4" Male, Female Swivel	160mm																																																					
3ML & 3FL = 3/4" Male, Female Swivel	000mm																																																					
IMF = In Port Male / Out Port Female	000mm																																																					
IFM = In Port Female / Out Port Male	000mm																																																					
4TS = 1/4" Tube Stubs	94mm																																																					
2TS = 1/2" Tube Stubs	120mm																																																					
3TS = 3/4" Tube Stubs	160mm																																																					
S = Cv 0.06 Standard (Inlet 3000psi) (1/4")																																																						
O = Cv 0.2 Optional (1/4")																																																						
S = Cv 0.2 Standard (3/8")																																																						
S = Cv 0.5 Standard (1/2")																																																						
O = Cv 1.0 Optional (1/2")																																																						
S = Cv 1.2 Standard (3/4")																																																						

### FLOW CHART

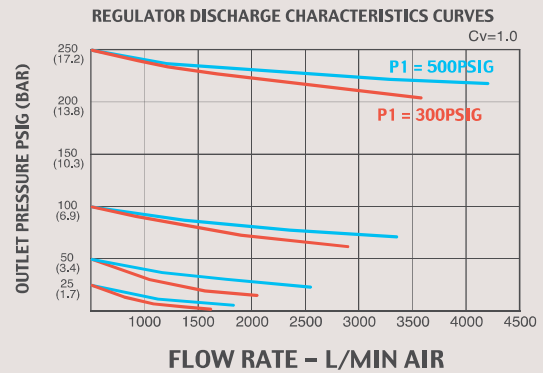
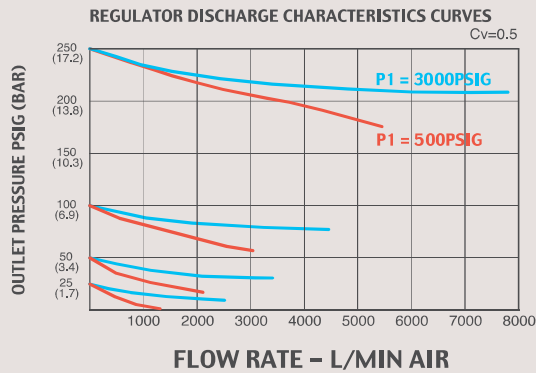
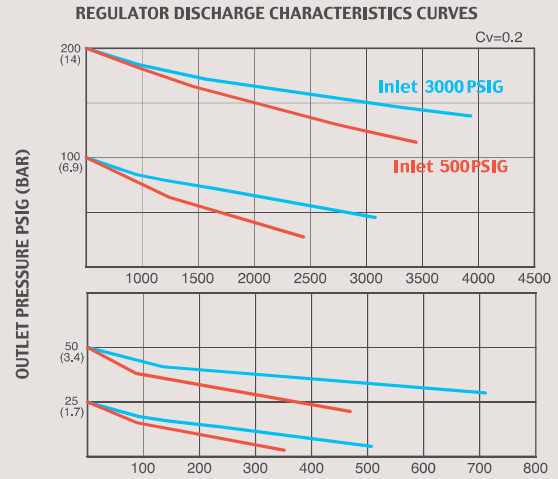
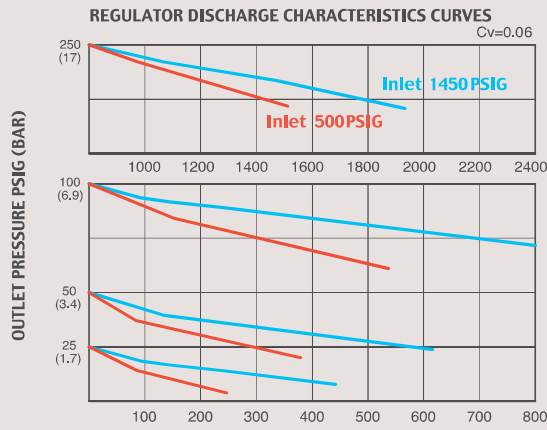

#### DRA200 Series 1/4" & 3/8"

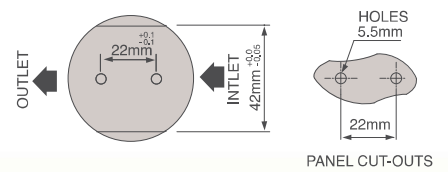
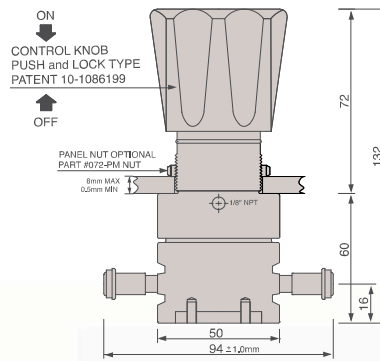
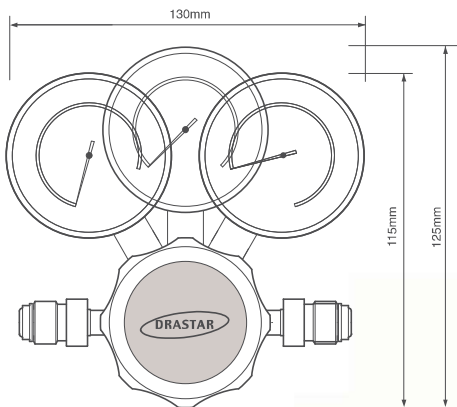

#### DRA200 Series 1/2" & 3/4"

